

Excel Vertical Plastic Hoops 65mm (2-Pack)



Item Code: 100-048



✕ Plastic construction

✕ Sold in pairs

✕ 77 mm cable rings

✕ Attached with the same bolt as the 100-040 uses

✕ CIBSE TM65 Embodied Carbon: 0.421 kg CO2e

Product Overview

Excel cable management rings for use in conjunction with the Excel V panel to ensure the cables can be managed out to edge of a data rack without the need to use a 19" management panel and save on U space.

Product Specifications

Feature	Values
Model	Jumper ring (V Panel)
Material	Plastic
Suitable for 19 inch mounting	no
Number of rack units (RU)	1

Excel Vertical Plastic Hoops 65mm (2-Pack)

Item Code: 100-048



Product drawing

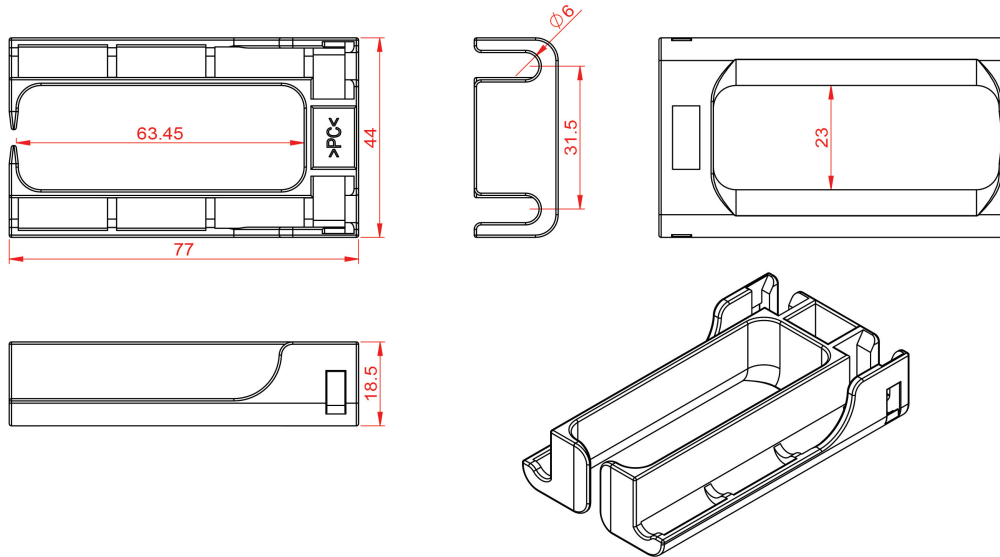

Standards

Applicable standard	Detail
RoHS-II/-III (2011/65/EU & 2015/863): 2023	Our products, demonstrate full adherence to the regulatory stipulations of the EU Directive 2011/65/EU (RoHS-II) and its corresponding delegated directive 2015/863 (RoHS-III).
WFD: 2023	Compliant to Waste Framework Directive
SCIP: 2023	Compliant - Does Not Contain Substances of Concern In articles as such or in complex objects (Products)
POPs (EU) No 2019/1021	EU Regulation for the restriction of Persistent Organic Pollutants.

Part Number Table

Part Number	Description
100-048	Excel Vertical Plastic Hoops 65mm (2-Pack)

Excel is a world class premium performing end to end infrastructure solution designed, Manufactured, supported and delivered without compromise.

Contact us at sales@excel-networking.com



E&OE. Excel is a registered trade name of Mayflex Holdings Ltd.