

# Excel Curved Shutter for Keystone Jack 45 x 45 mm 2 Port Antibacterial

Item Code: 100-282-AB

**excel**  
without compromise.



✕ Accepts all Excel Keystone Jacks

✕ Available in 1 & 2 Port versions

✕ Directly mount in trunking

✕ Curved shape with large label field

✕ Anti-bacterial finish

## Product Overview

The Excel Curved 45 mm x 45 mm keystone shutters with anti-bacterial protection are available in 1 and 2 port versions. Each shutter will support all of the Excel keystone jacks enabling screened and unscreened Category 5e, 6 and 6A terminations to be presented in a uniform fashion.

Fixing clips are positioned on the rear of the shutter to allow the fitment to horizontally or vertically mounted trunking whilst maintain upright orientation of the shutter. Each port is protected with a curved, spring loaded shutter in matching material. The shutter comes complete with paper label and fitted clear window and meets Anti-Bacterial standards.

## Product Specifications

Feature	Values
Application	Mounting cover data connector
Material	Plastic
Colour	White
RAL-number (akin)	9016
Type of fastening	Engage (snap)
Number of modules (module system)	2
Width of device	45 mm
Height of device	45 mm

# Excel Curved Shutter for Keystone Jack 45 x 45 mm 2 Port Antibacterial

Item Code: 100-282-AB

**excel**  
without compromise.

## Product drawing

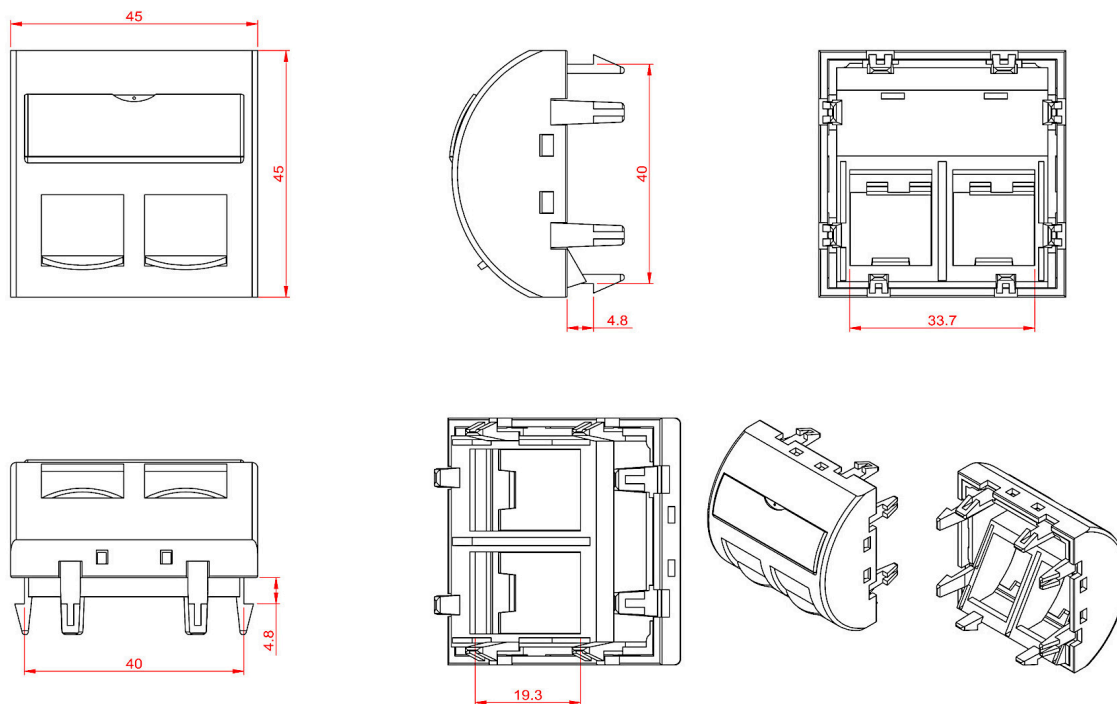

## Standards

Applicable standard	Detail
BSEN 60670-1:2005 + A1:2013	Boxes and enclosures for electrical accessories for household and similar fixed electrical installations general requirements
BSEN 61340-5-1:2007	Protection of electronic devices from electrostatic phenomena. General requirements apply to activities that: manufacture, process, assemble, install, package, label, service, test, inspect, transport or otherwise handle electrical or electronic parts, assemblies and equipment susceptible to damage by electrostatic discharges greater than or equal to 100 V human body model (HBM).
BSEN 60529:1992+A2:2013	Degrees of Protection provided by Enclosures ( IP CODE )
ISO 22196:2011	Measurement of antibacterial activity on plastics and other non-porous surfaces
RoHS-II/III (2011/65/EU & 2015/863): 2023	Our products, demonstrate full adherence to the regulatory stipulations of the EU Directive 2011/65/EU (RoHS-II) and its corresponding delegated directive 2015/863 (RoHS-III).
WFD: 2023	Compliant to Waste Framework Directive

# Excel Curved Shutter for Keystone Jack 45 x 45 mm 2 Port Antibacterial

Item Code: 100-282-AB



SCIP: 2023

Compliant - Does Not Contain Substances of Concern In articles as such or in complex objects (Products)

POPs (EU) No 2019/1021

EU Regulation for the restriction of Persistent Organic Pollutants.

## Part Number Table

Part Number	Description
100-282-AB	Excel Curved Shutter for Keystone Jack 45 x 45 mm 2 Port Antibacterial

Excel is a world class premium performing end to end infrastructure solution designed, Manufactured, supported and delivered without compromise.

Contact us at [sales@excel-networking.com](mailto:sales@excel-networking.com)



E&OE. Excel is a registered trade name of Mayflex Holdings Ltd.