

Excel Vertical Management Ring Large Black

Item Code: 100-924



- ✕ 144 mm Cable Ring
- ✕ Supplied with mounting hardware
- ✕ 2 sizes available
- ✕ Manage over 100 patch leads
- ✕ ABS plastic
- ✕ 25 Year system warranty
- ✕ CIBSE TM65 Embodied Carbon: 0.522 kg CO2e

Product Overview

The Excel Vertical Cable Management rings have been introduced to complement the Patch Rack System however they can be installed in all cabinets to assist in the management of patch cables.

Manufactured from high quality ABS plastic, the larger rings have the capacity to manage over 100 patch leads. They come complete with cage nuts and screws to mount them to the side of the 19" profiles of the Excel Environ cabinets or the Patch Rack.

Product Specifications

Feature	Values
Model	Cable management ring
Material	Plastic
Width	144 mm

Product drawing (medium size)

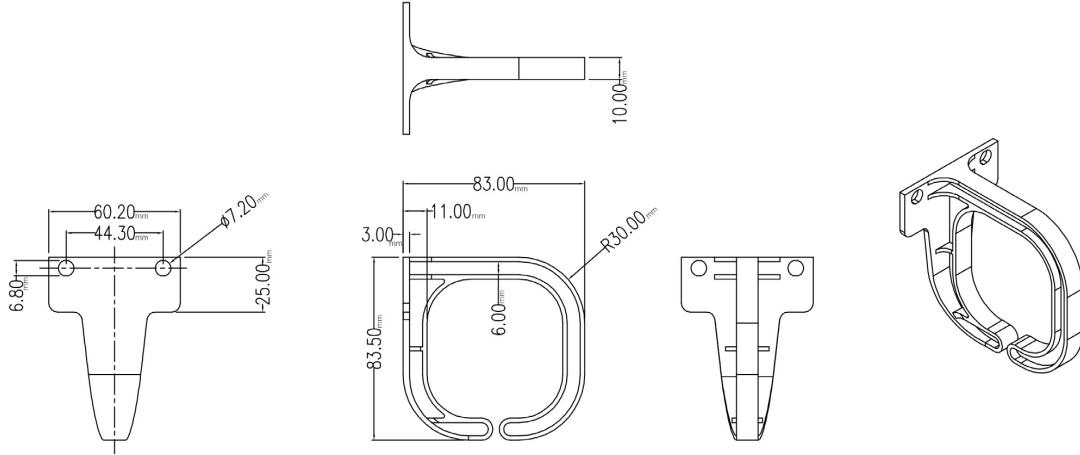

Product drawing (large size)

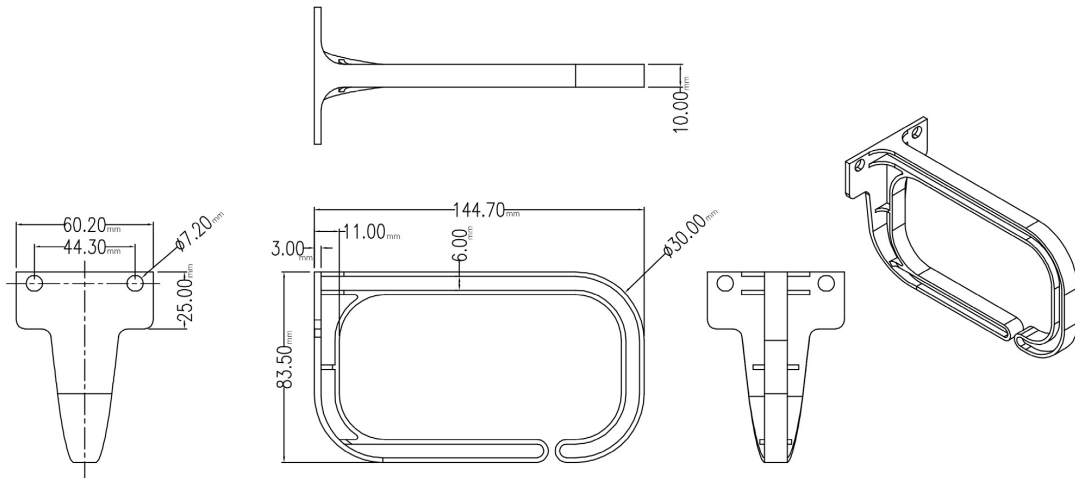

Standards

Applicable standard	Detail
RoHS-II/-III (2011/65/EU & 2015/863): 2023	Our products, demonstrate full adherence to the regulatory stipulations of the EU Directive 2011/65/EU (RoHS-II) and its corresponding delegated directive 2015/863 (RoHS-III).
WFD: 2023	Compliant to Waste Framework Directive
SCIP: 2023	Compliant - Does Not Contain Substances of Concern In articles as such or in complex objects (Products)

Excel Vertical Management Ring Large Black

Item Code: 100-924



POPs (EU) No 2019/1021

EU Regulation for the restriction of Persistent Organic Pollutants.

Part Number Table

Part Number	Description
100-923	Excel Vertical Management Ring Medium Black
100-924	Excel Vertical Management Ring Large Black

Excel is a world class premium performing end to end infrastructure solution designed, Manufactured, supported and delivered without compromise.

Contact us at sales@excel-networking.com



E&OE. Excel is a registered trade name of Mayflex Holdings Ltd.